

Indoor Positioning with Sensor Fusion based on Bayesian Filtering

Bernhard Krach, Mohammed Khider, Kai Wendlandt, and Patrick Robertson
 Institute of Communications and Navigation
 German Aerospace Center (DLR)

Abstract:

Positioning in buildings and other environments where GNSS reception is difficult will require a combination of sensors and other information such as building plans in order to function accurately. We are pursuing sensor fusion approaches that combine GNSS, foot mounted inertial sensors electronic compasses, baro-altimeters, maps and active RFID tags. A particularly powerful combination is INS step measurement in conjunction with maps which can converge to the correct position after less than a minute of motion. We have developed a two-layer sensor fusion architecture that operates with a Kalman filter where possible, and fuses other sensors and maps at a higher-level, lower rate, particle filter. In buildings, a few dispersed RFID tags or even moderately GNSS reception can significantly aid the overall positioning.

Sensor Implementation:

→ Shoe-mounted inertial sensors enable accurate pedestrian dead-reckoning (accuracy degrades over time and travelled distance)

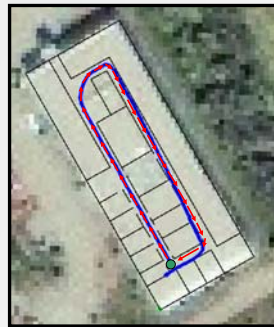

— Estimate — Reference walking track
 ● Start/Stop

→ RFID reader and distributed tags: positioning based on tag ID and received signal strength (RSS)

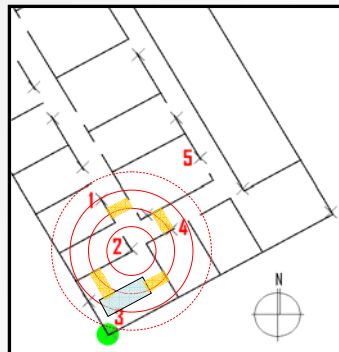

→ Bluetooth GPS receiver for absolute positioning in mild indoor conditions



→ 3D electronic compass for attitude and posture determination



→ Barometric altimeter gives altitude with respect to nominal pressure at sea level



Combining Sensors:

→ Combining complementary sensors through an optimal sensor fusion algorithm leads to synergetic effects and thus improves positioning

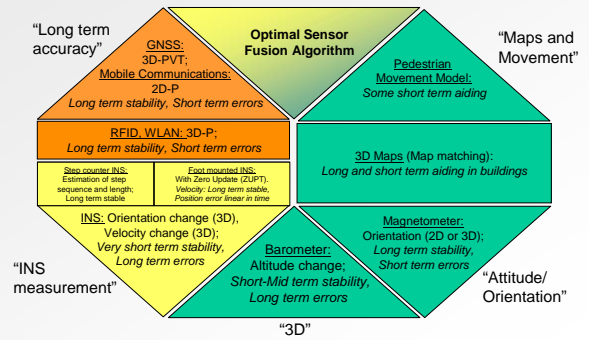

Sensor Fusion Framework Architecture:

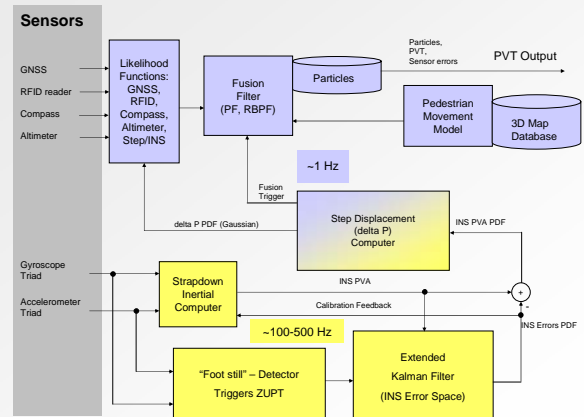

Map-Aided Dead-Reckoning:

→ Combining foot-mounted inertial sensor based dead-reckoning with a map information based human movement model

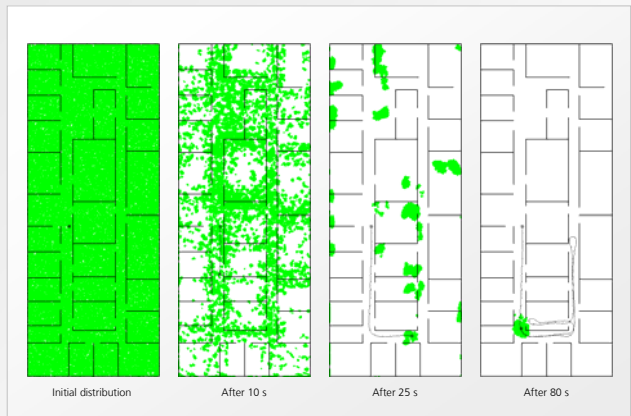

Integration with map-matching in the particle filter: A pedestrian wearing the foot-mounted sensor walked the indicated track (black line). At each figure the posterior position estimate (green) becomes increasingly accurate, after 80s it is unimodal.